

CAE

CIVIL AVIATION

Bombardier

Learjet 35/36

Business Aircraft Maintenance Training



Confidence through
smarter training



Delivering the very BEST AVIATION MAINTENANCE TRAINING while RAISING INDUSTRY STANDARDS

Why you should choose CAE as your maintenance training provider

Proper aircraft and helicopter maintenance is vital to ensure the safety of business air travel. The daily challenges of operating a successful operation in aviation can only be met with adequate preparation and training to keep pace with the continual advancements of the complex technologies found in this constantly changing field.

Let us deliver on the investment of your most valued, strategic asset: your team. CAE can elevate the skillsets of your entire staff, regardless of experience level. We will help attract and prepare new talent with our accelerated learning systems.

With CAE's approach to complete flexibility on multiple fronts: course type, training site, and targeted solutions -we lower downtime, while increasing productivity.

- Realize increased technician potential with our precise and proven course materials and training methods
- Improve your aircraft dispatch rates by building technician confidence with CAE's highly effective, application-oriented, interactive instruction techniques
- Experience higher savings by targeting your training budget at programs which deliver unmatched quality, safety, and results

As a long-standing leader in the field of simulation and other advanced, digital training solutions, CAE is your best choice for improving safety and removing the obstacles which impede your progress. Offering superior maintenance training for over 20 years, we invite you to keep your technicians' skillsets current across a full suite of learning programs for most major OEMs, including Bombardier, Dassault, Embraer, Gulfstream.

With a global network of training centers, highly skilled instructors, and advanced training tools, look to CAE for flexible, relevant, and leading-edge business aircraft maintenance training solutions to enhance safety, efficiency, and readiness for your staff and fleet.

We are here to ensure your success.



TABLE OF CONTENTS	Page
CAE Teaching Objectives.....	2
Student Training Expectations.....	2
Classroom Discussion.....	3
Applied Training Techniques.....	3
Total Training Environment Flexibility	3
Initial with Honeywell TFE731 engines Maintenance Training Summary.....	4
Maintenance Systems Maintenance Training Summary	5
REALcase Update Maintenance Training Summary	6
Avionics Maintenance Training Summary	7
Electrical Interface Maintenance Training Summary	8
Familiarization Maintenance Training Summary	9
Line Maintenance Training Summary	10

CAE Teaching Objectives

To provide the experienced aircraft technician with knowledge of major systems and major component description, location, and operation; servicing; safety precautions; and troubleshooting to support a typical through-flight maintenance and inspection schedule in accordance with the manufacturer’s Aircraft Maintenance Manual.

Student Training Expectations

Each student should be a Part 66/Part 65 certified Airframe and Powerplant Mechanic or have equivalent experience on similar type aircraft.

Courses are conducted in English and attendees must have a good working knowledge of the language enabling them to speak, read, and write in this language.

The candidate is required to attend at least 95% of all course content in order to successfully complete the training. A mark of 75% or above is needed for any written exams.

Click on CAE logo to return to this page

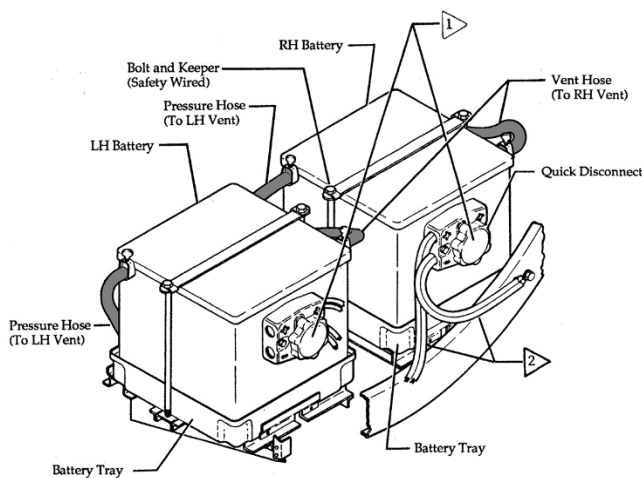
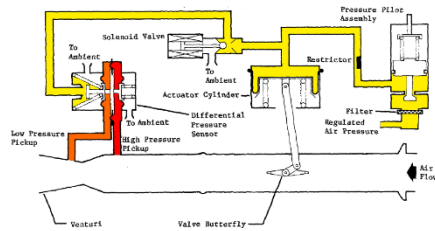
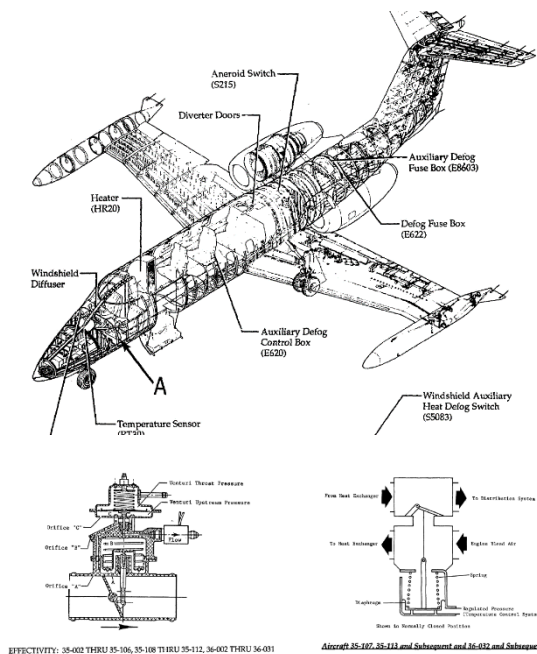

Classroom Discussion

This phase covers classroom lectures comprising:

- in-depth description of systems
- operation, identification, and location of principle components
- maintenance, inspection, and ground run procedures
- routing and theoretical troubleshooting
- preventive maintenance
- safety precautions

The students are encouraged to participate throughout these sessions, which are often interspersed with review questions. This phase may also include visits to the flight line facilities where students are exposed to the real aircraft, system components.

Applied Training Techniques

The practical phase is conducted by an experienced instructor using “hands on” training modules, Fixed Training Device (FTD) or Full Flight Simulator (FFS) and where applicable: real aircraft components. The students are involved in practical tasks associated with maintenance of the aircraft such as:

- Practical troubleshooting
- Servicing Procedures
- System start-up and shut-down procedures
- Normal, Abnormal and Emergency Procedures

This enables the students to apply knowledge gained during other learning phases of this course. A minimum of 5% of the course shall be conducted using possible combinations of a FTD, FFS, the aircraft, mock-ups, or actual aircraft components.

Total Training Environment Flexibility

Courses may be conducted at most of our global network of training centers (including CAE’s hybrid classrooms), at a customer’s facility (off-site), or via distance learning / Live Remote Training (LRT).



Initial with Honeywell TFE731 engines Maintenance Training Summary

Course Description

Our Initial-level maintenance training course covers all applicable ATA chapters, addressing aircraft systems' theory, operation, inspection, and servicing. The course examines LRU troubleshooting from a theoretical and practical perspective.

Hands-on sessions will be conducted on available aircraft to acquire an applied understanding of aircraft systems, and to participate in effective maintenance practices.

This comprehensive class is the ideal way to introduce technicians to transitions within the fleet.

Course Objectives

The Initial course furnishes the experienced technician with sufficient information to carry out the required maintenance, repair, and troubleshooting necessary to certify the continued airworthiness of the aircraft's mechanical and avionics systems.

Course Total Time60 Hrs / 10 Days

SUBJECT	ATA
Introduction	1
Flight Deck	2
Times and Limitations	5
Aircraft General	6-12
Air Conditioning	21
Auto Flight	22
Communication	23
Electrical Power	24
Equipment Furnishings	25
Fire Protection	26
Flight Controls	27
Fuel	28
Hydraulic Power	29
Ice & Rain System	30
Indicating & Recording	31
Landing Gear	32
Lighting	33
Navigation / RVSM	34
Oxygen	35
Pneumatic	36
Water & Waste	38
Structures	51-57
Power Plant	71-80

Regulatory Compliance

CAE is authorized to conduct this course under the following Regulatory Authority approvals:

- TC [Canada]



Maintenance Systems Maintenance Training Summary

Course Description

Our Initial-level maintenance training course covers all applicable ATA chapters, addressing aircraft systems' theory, operation, inspection, and servicing. The course examines LRU troubleshooting from a theoretical and practical perspective.

Hands-on sessions will be conducted on available aircraft to acquire an applied understanding of aircraft systems, and to participate in effective maintenance practices.

This comprehensive class is the ideal way to introduce technicians to transitions within the fleet.

Course Objectives

The Initial course furnishes the experienced technician with sufficient information to carry out the required maintenance, repair, and troubleshooting necessary to certify the continued airworthiness of the aircraft's mechanical and avionics systems.

Course Total Time60 Hrs / 10 Days

SUBJECT

ATA

A/C General/Pubs.....	00-05-12-20
Air Conditioning	21
Auto Flight	22
Communication.....	23
Electrical.....	24
Equipment & Furnishings	25
Fire Protection	26
Fuel	28
Ice & Rain.....	30
Indicating & Recording	31
Lights.....	33
Navigation.....	34
Pneumatics	36
APU.....	49
Flight Controls.....	27
Hydraulics	29
Landing Gear	32
Oxygen.....	35
Structures	51-57
Powerplant.....	71-80

Regulatory Compliance

CAE is authorized to conduct this course under the following Regulatory Authority approvals:

- FAA [USA]



REALcase Update Maintenance Training Summary

Course Description

The REALcase concept utilizes fleet operational data/information that is acquired from the manufacturer and/or operators, spanning the 12 to 18-month period preceding the course. Information relevant to the operation, maintenance and troubleshooting of the aircraft, is presented during the course for review, analysis, and discussion. Emphasis is placed on applicable maintenance considerations, manufacturer recommendations, troubleshooting and dispatch decisions.

Course Objectives

- Better understand the latest in-service difficulties and/or operational issues experienced by fleet operators and reported to the OEM
- Understand and apply the latest manufacturer's documentation, recommendations, and operational maintenance procedures
- (When applicable) be acquainted with recent engine Service Bulletins, Service Information Letters, Enhancements / Options, Services Advisories, etc. pertaining to this engine
- Have increased technical understanding of the aircraft's core systems (with additional emphasis on particular systems the student may wish to focus on)
- Better understand and troubleshoot and/or isolate failures of specific systems or components in accordance with maintenance procedures and applicable documentation

Course Total Time 30 Hrs / 5 Days

SUBJECT

ATA

Introduction	1
Times and Limitations	5
Aircraft General	6-12
Air Conditioning	21
Auto Flight	22
Communication	23
Electrical Power	24
Fire Protection	26
Flight Controls	27
Fuel	28
Hydraulic Power	29
Ice & Rain System	30
Indicating & Recording	31
Landing Gear	32
Lighting	33
Navigation / RVSM	34
Oxygen	35
Pneumatic	36
Power Plant	71-80

Regulatory Compliance

CAE is authorized to conduct this course under the following Regulatory Authority approvals:

- FAA [USA]



Avionics Maintenance Training Summary

Course Description

The Avionics course furnishes the experienced aircraft technician with information pertaining to operation of the display, communication, navigation (short-range and long-range), and the automatic flight control (flight guidance) systems. It provides sufficient working knowledge of these systems to allow the technician to participate in troubleshooting at the line maintenance level.

All training is conducted to Level 3, according to ATA specification 104. A good understanding of basic avionics is suggested. (CAE also offers 40-hour classes in each of the following: Avionics Essentials Part I and Part II.)

Course Total Time 30 Hrs / 5 Days

SUBJECT

ATA

Introduction	1
Auto Flight	22
Communication	23
Equipment Furnishings	25
Indicating & Recording	31
Navigation / RVSM	34

Course Objectives

After completion of this Avionics course, the student should be able to:

- Use and interpret the appropriate technical publications.
- Describe the purpose and interfaces of each system and associated components
- Explain the operation of each main system and associated components
- Identify and locate the major components associated with each system
- Identify, locate and describe the system controls and indications
- Troubleshoot and isolate failures of specific systems or components

Regulatory Compliance

CAE is authorized to conduct this course under the following Regulatory Authority approvals:

- TC [Canada]



Electrical Interface Maintenance Training Summary

Course Description

This course is a combination of recurrent, in-depth troubleshooting practices, and tracing wiring diagrams. We employ a “white glove” approach where the majority of investigative work can be performed without using tools. Troubleshooting is performed from the cockpit level, using indication messages, support documentation, and wiring diagrams.

This is an intensive session with active classroom participation and considered an essential course for all proactive technicians familiar with the aircraft.

Course Objectives

This course provides the student with in-depth instruction on aircraft’s electrical system and its interface with other aircraft systems. CAE furnishes the experienced technician with information to carry out troubleshooting and test procedures necessary to maintain the aircraft electrical systems. The course is based on the use of the manufacturers maintenance manuals and wiring diagrams, SmartFix Plus (SFP), synoptic pages, and the Maintenance Diagnostic Computer (MDC) to verify system status and isolate faults.

Course Total Time 30 Hrs / 5 Days

SUBJECT

ATA

Introduction	1
Flight Deck	2
Aircraft General	6-12
Air Conditioning	21
Auto Flight	22
Communication	23
Electrical Power	24
Equipment Furnishings	25
Fire Protection	26
Flight Controls	27
Fuel	28
Hydraulic Power	29
Ice & Rain System	30
Indicating & Recording	31
Landing Gear	32
Lighting	33
Navigation / RVSM	34
Oxygen	35
Pneumatic	36
Structures	51-57
Power Plant	71-80

Regulatory Compliance

CAE is authorized to conduct this course under the following Regulatory Authority approvals:

- TC [Canada]



Familiarization Maintenance Training Summary

Course Description

This maintenance course will help technicians understand the aircraft systems, servicing, and practical know-how to maintain the aircraft properly. The course is for the technician who has similar aircraft experience, yet also for the manager or scheduler who wants a better understanding of the aircraft.

If the aircraft is available, actual hands-on practices will be conducted to ensure a complete understanding of aircraft systems and "real-world" maintenance practices.

The Familiarization class offers an excellent way to extend technician productivity.

Course Objectives

The General Familiarization course provides the applicant with a general description of the aircraft capabilities, systems, avionics, power plant, maintenance, and support requirements.

Course Total Time 30 Hrs / 5 Days

SUBJECT

ATA

Introduction	1
Flight Deck	2
Checklists	3
Airworthiness Limitations	4
Times and Limitations	5
Aircraft General	6-12
Air Conditioning	21
Auto Flight	22
Communication	23
Electrical Power	24
Equipment Furnishings	25
Fire Protection	26
Flight Controls	27
Fuel	28
Hydraulic Power	29
Ice & Rain System	30
Indicating & Recording	31
Landing Gear	32
Lighting	33
Navigation / RVSM	34
Oxygen	35
Pneumatic	36
Water & Waste	38
Structures	51-57
Power Plant	71-80

Regulatory Compliance

CAE is authorized to conduct this course under the following Regulatory Authority approvals:

- TC [Canada]



Line Maintenance Training Summary

Course Description

The line maintenance course is a condensed session enabling technicians to understand aircraft systems and servicing with an emphasis on practical experience to build aircraft maintenance skills. This training differs from the traditional Maintenance Initial in that it is designed to be a more focused curriculum for technicians that may already have initial exposure and/or experience on the particular aircraft.

Moderate troubleshooting is stressed and reinforced with actual hands-on sessions on available aircraft. Active student participation provides a better understanding of aircraft systems and effective maintenance practices. For operations with technician scheduling and cost limitations, this option creates a highly productive solution.

Course Objectives

After completion of this Line Maintenance course, the student should be able to:

- Use and interpret the appropriate technical publications
- Describe the purpose and interfaces of each system and associated components
- Explain the operation of each main system and associated components
- Identify and locate the major components associated with each system
- Identify, locate, and describe the system controls and indications
- Troubleshoot and isolate failures of specific systems or components

Course Total Time 30 Hrs / 5 Days

SUBJECT

ATA

Introduction	1
Aircraft General	6-12
Air Conditioning	21
Auto Flight	22
Communication	23
Electrical Power	24
Fire Protection	26
Flight Controls	27
Fuel	28
Hydraulic Power	29
Ice & Rain System	30
Indicating & Recording	31
Landing Gear	32
Lighting	33
Navigation / RVSM	34
Oxygen	35
Pneumatic	36
Power Plant	71-80

Regulatory Compliance

CAE is authorized to conduct this course under the following Regulatory Authority approvals:

- FAA [USA]



2929 W. Airfield Dr.
Dallas, Texas 75261

+1 (800) 527-2463 +1 (972) 456-8000 +44 1444-247535

<https://www.cae.com/contact-us/civil-aviation/aircraft-maintenance-training-contacts>